



DR Series

Projector Horns For Uniform Sound Dispersions



DR-54

Features

- Multi-Purpose Reflex Sound Horns for High Intelligibility Sound Distribution and Voice and Signal Applications
- Accepts All Standard High Efficiency Compression Drivers with 1 3/8" - 18 Male Threads
- Exponentially-Flared for Uniform Sound Distribution
- Weatherproof, All-Metal Construction for Year Round Use

Applications

DR Series double re-entrant horns have proven their capability and ruggedness in permanent and temporary applications in recreational, commercial and industrial applications for over sixty years. When used with PD or SD Series compression drivers, they assure intelligible audio transmission over long distances or through high background noise levels and are consistently recommended for sport facilities, amusement parks, church towers, warehouses, factories, military sites, transportation terminals, and other environmentally-demanding locations.

General Description

Atlas Sound DR Series double re-entrant horns are designed for use with compression driver units to offer superior music and voice communications over distance and ambient noise. The circular projectors are equipped with a resonance damping ring for best response through an extended frequency range. Weather-resistant units will accommodate Atlas Sound PD & SD Series compression drivers or any driver with standard 1 3/8" -18 male thread coupling. The integral "U-type" steel mounting bracket provides maximum directional aiming flexibility and enhances installation capability when used outdoors or in industrial environments. The rugged all-metal, exponentially-flared horns are finished in durable grey epoxy. Loudspeaker stands feature telescoping action, positive-locking hardware and diecast safety collar and offer vertical extension range from 5 to 8 feet (1524 to 2438mm) height.

Specifications

DR-32

Dispersion	95°
Low End Cut-Off	190Hz
Air Column Length	2 1/2' (762mm)
Sound Level*	*
Directivity Factor (Q)**	10.7
Weight	11lbs. (4.9kg.)

DR-42

Dispersion	85°
Low End Cut-Off	140Hz
Air Column Length	3 1/2' (1067mm)
Sound Level*	*
Directivity Factor (Q)**	14.7
Weight	13lbs. (5.9kg.)

DR-54

Dispersion	75°
Low End Cut-Off	115Hz
Air Column Length	4 1/2' (1372mm)
Sound Level*	*
Directivity Factor (Q)**	16.8
Weight	20lbs. (9.0kg.)

DR-72

Dispersion	65°
Low End Cut-Off	85Hz
Air Column Length	6 1/2' (1981mm)
Sound Level*	*
Directivity Factor (Q)**	19.3
Weight	25lbs. (11.3kg.)

* Determined by associate compression driver (see chart on reverse side of this sheet).

** One octave band of pink noise at 1 kHz.

©2011 Atlas Sound L.P. All rights reserved. Atlas Sound and Strategy Series are trademarks of Atlas Sound L.P. All other trademarks are the property of their respective owners. AT5004071 RevB 6/11

Sound Pressure Levels of DR Series Models with Atlas Sound Compression Drivers

DR-32	SPL
Model PD-30T	124dB
Model PD-5VH/PD-5VT	124dB
Model PD-60/PD-60T	130dB
SD-70	129dB
Model PD75T	131dB
DR-42	SPL
Model PD-30T	125dB
Model PD-5VH/PD-5VT	125dB
Model PD-60/PD-60T	131dB
SD-70	130dB
Model PD75T	132dB
DR-54	SPL
Model PD-30T	125dB
Model PD-5VH/PD-5VT	127dB
Model PD-60/PD-60T	132dB
SD-70	132dB
Model PD75T	133dB
DR-72	SPL
Model PD-30T	127dB
Model PD-5VH/PD-5VT	129dB
Model PD-60/PD-60T	135dB
SD-70	134dB
Model PD75T	136dB

Architect and Engineer Specifications

The reflex sound projector shall be Atlas Sound Model _____ (Model DR-32, DR-42, DR-54 or DR-72) or approved equal. The weatherproof exponential-flared unit shall have a rated low frequency cut-off of _____ and sound dispersion of _____. Air column length shall be _____. It shall accommodate compression driver units with standard 1 3/8" -18 male threads. The horn, less driver shall measure _____ and weigh _____. "U-type" steel mounting bracket shall be provided (for mounting). Finish shall be grey epoxy.

DR Series Dimensions

Model	A	B	C
DR-32	12½" (319mm)	16½" (419mm)	10½"(267mm)
DR-42	16" (406mm)	21" (533mm)	13 ¾"(349mm)
DR-54	19" (483mm)	26" (660mm)	17" (432mm)
DR-72	28" (711mm)	31" (787mm)	24¼" (616mm)

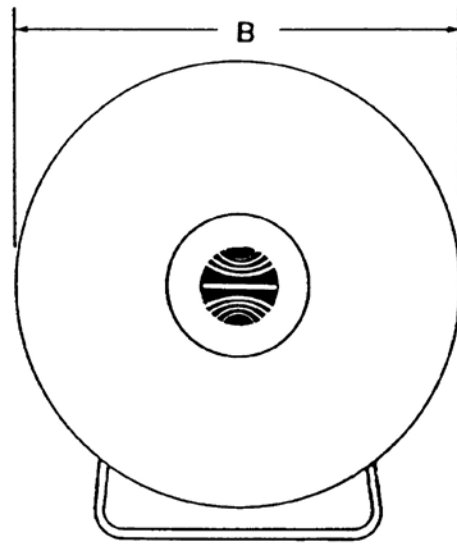
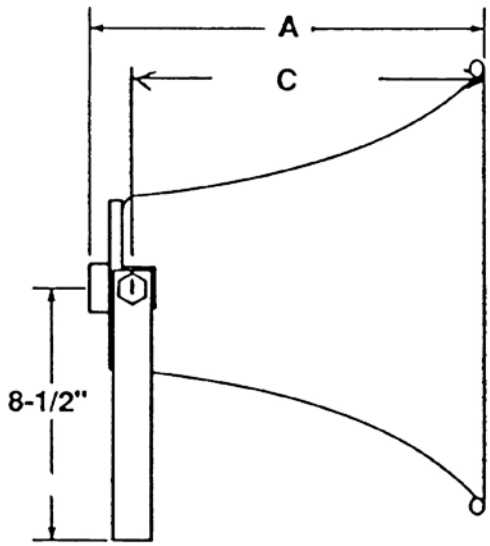

MOUNTING BRACKET DIMENSIONS

